

Wing Nuts

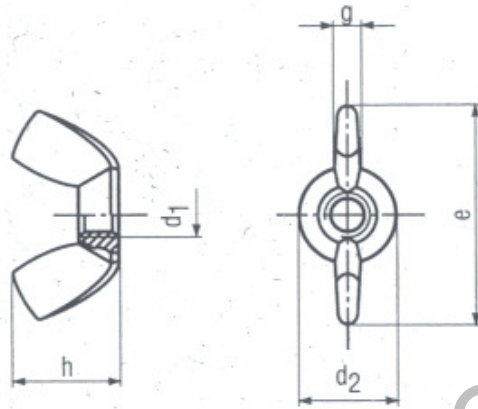

d1	e		h		d2		g	
	Min.	Max.	Min.	Max.	Min.	Max.	Min.	Max.
M3	16.5	20.0	7.6	9.6	8.7	9.0	1.9	2.9
M4	20.5	23.5	9.5	11.5	8.7	10.3	2.1	3.1
M5	20.5	23.5	9.5	11.5	8.7	10.3	2.1	3.1
M6	25.7	28.7	11.7	13.7	11.1	12.7	2.5	3.5
M8	28.6	32.0	13.6	16.0	12.6	14.4	2.8	3.8
M10	33.6	38.0	16.0	19.0	14.4	16.2	3.5	4.5
M12	45.0	50.4	21.0	25.1	19.5	23.5	4.0	5.5

Specification Requirements.

- Dimensions: See dimensions above.
- Threads: 6H
- Material & Mechanical Properties: Carbon steel. HRB 72 to HRC 30.